

INSTRUCTION MANUAL
TIPPING BUCKET RAINGAUGE
MODEL TB4

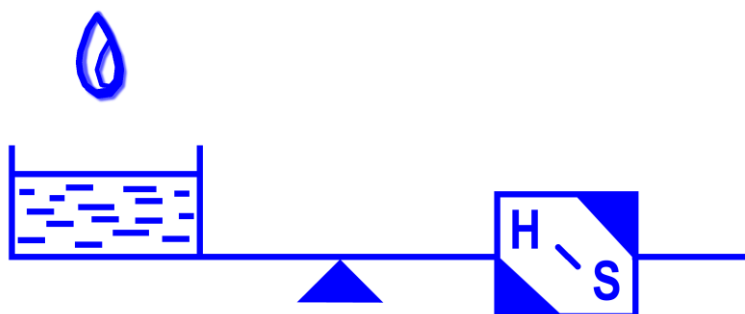

QUALITY SYSTEM
ISO
9001
2008
CERTIFIED

HYDROLOGICAL SERVICES PTY LTD
PO BOX 332, LIVERPOOL B.C NSW 1871, AUSTRALIA
Phone:(Int.) 612 9601 2022 Fax: :(Int.) 612 9601 6971
Phone:(Nat.) (02) 9601 2022 Fax: :(Nat.) (02) 9601 6971
Email: sales@hydrologicalservices.com
Web: www.hydrologicalservices.com

HYDROLOGICAL SERVICES

Contents

I	HYDROLOGICAL SERVICES STANDARD WARRANTY TERMS.....	3
II	GENERAL	4
III	UNPACKING YOUR TB4 RAINGAUGE	4
IV	SPECIFICATION.....	5
V	INSTALLATION	6
VI	TEST OPERATION	7
VII	MAINTENANCE.....	8
VIII	ELECTRICAL.....	10
IX	CALIBRATION	10
X	TB4 PART LIST	11
	TB4 Base Part List.....	12
	TB4 Bucket Part List	13
	Syphon Part List	14
	Filter Part List.....	15
	Enclosure Part List.....	16
XI	FIELD CALIBRATION DEVICE	17

HYDROLOGICAL SERVICES

I HYDROLOGICAL SERVICES STANDARD WARRANTY TERMS

WARRANTY, DISCLAIMER AND LIMITATION OF LIABILITY:

We warrant this product to be free from defects in material and workmanship for a period of three years from the date of shipment hereof or its total rated life, whichever first occurs. During the warranty period, we will repair or replace this product if it is returned to us with shipping charges prepaid and we determine it to be defective. This warranty shall not apply if this product has been subjected to misuse, negligence, accidents, or misapplied, or modified or repaired by unauthorised persons, or improperly installed, and we shall not be liable to any person for personal injury or property damage caused by such a product.

All other warranties, express and implied, including warranties of MERCHANTABILITY and FITNESS FOR A PARTICULAR PURPOSE, are disclaimed. All other remedies and liabilities, including incidental, consequential, and special damages, losses, and expenses, are excluded.

Note: It is Hydrological Services' policy to support all of our products. If design or workmanship problems arise after this statutory warranty period we request that you contact us.

HYDROLOGICAL SERVICES

TIPPING BUCKET RAINGAUGE MODEL TB4

II GENERAL

The Hydrological Services Tipping Bucket Raingauge (TB4) is recognised as the standard for measuring rainfall and precipitation in remote and unattended locations.

The TB4 raingauge operates on the tipping bucket principle. A receiver of 200mm diameter collects the rainfall which is strained by a metal gauze before being passed to the tipping bucket measuring system. Tips of the bucket occur with each 0.2mm, 0.5mm 1.0mm or 0.01inch of precipitation collected and a reed switch detects these events and produces a momentary contact closure signal for:

- X logging in our Rainfall Data Logger
- X transmission by our Radio Reporting Raingauge, or
- X display on our Rainfall Counter.

III UNPACKING YOUR TB4 RAINGAUGE

This package should contain:

- X TB4 Raingauge
- X TB311/5 5 metre connecting lead

Please verify you have received these items and that the Tipping Bucket Raingauge resolution is as ordered.

To prepare the Tipping Bucket Raingauge for installation:

- X lift the unit from the carton and place on secure surface
- X remove polythene bag
- X loosen the three enclosure securing screws and back them off until screw head is clear of the enclosure.
- X lift the enclosure from the gauge
- X carefully remove the elastic band/support pad from the bucket.

Your Tipping Bucket Raingauge is now ready for installation.

HYDROLOGICAL SERVICES

IV SPECIFICATION

Receiver: 200 mm \pm 0.3 diameter heavy duty cast aluminium, Powder coated.

Bucket capacity: Plastic: 0.2 mm, 0.5 mm, 0.01 inch of rainfall.
Metal: 1.0 mm of rainfall

Sensitivity: one tip.

Maximum intensity: 700 mm / hr.

Calibration accuracy:

TB4 bucket capacity	Measuring range	Accuracy
0.1mm, 0.2mm, 0.01" & 1.0 mm	0-250mm/hr	\pm 2 %
	250-500mm/hr	\pm 3 %

Long term stable calibration.

Humidity: 0 to 100 %

Temperature: - 20 to +70°C

Contact system: dual reed switches potted in soft silicon rubber with varistor protection.
 -Max Capacity: 0.5 amp, 12 Volts D.C.
 - Resistance: Initial contact resistance 0.1 OHMS
 - M.T.B.F: 10^8 to 10^9 Operations

Syphon: 0.4 mm (12ml) capacity of rainfall - made from brass with a non hydroscopic outer case. The syphon can be dismantled for routine cleaning and servicing.

Bucket: Two types of buckets, synthetic ceramic coated brass bucket balanced to + 0.05 gms for 1mm bucket only, and injection moulded non hydroscopic plastic ABS chrome plated UV stabilised balanced + 0.05gms for 0.2mm, 0.5mm and 0.01".

Base: injection moulded non-hydroscopic ABS plastic UV stabilised.

Level: bulls eye level fitted to base.

Mounting holes: three 10 mm diameter mounting holes at 234 mm PCD in feet moulded to outside diameter of base.

Drain fittings: to attach 12 mm inside diameter tubing, to catch rainfall after passing through buckets.

Bucket pivot system: two stainless spring steel rolling bearings, clamped at 90 degrees to bucket stainless spring steel axle.

Insect covers: stainless steel mesh on all openings to prevent insects and ants entering gauge.

HYDROLOGICAL SERVICES

Outer enclosure:	keyed to enable the release of the outer enclosure without the need for the removal of the three securing screws.
Height:	315mm
Weight:	2 kg
Packed Dimensions:	3 kg 0.03m ³

V INSTALLATION

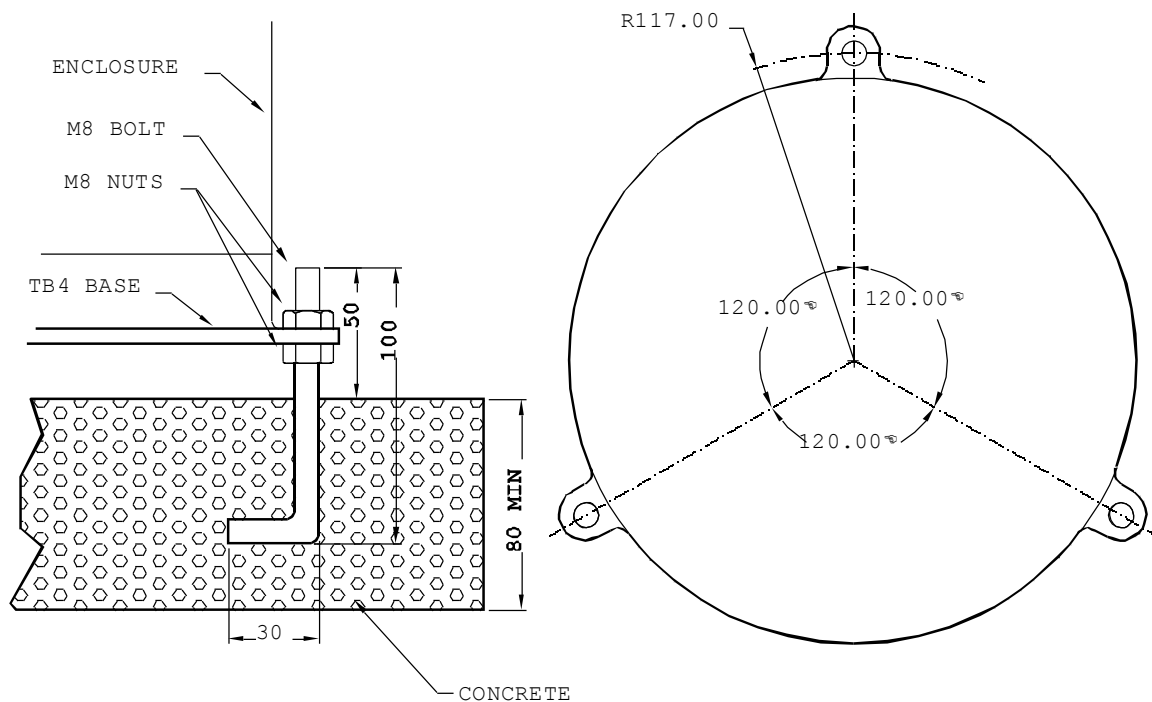

DIAGRAM 1

(i) Site Selection

Rainfall measurements are intended to be representative of the actual rain falling on a given area. Some of the more important factors which influence the representativeness of a gauge are as follows:

- X Site the gauge on level ground where possible. Avoid sloping sites.
- X Site should have adequate protection from strong winds.
- X Site should be free of large obstructions such as buildings and trees.
- X Provide suitable ground surface to avoid splashing into the gauge.

HYDROLOGICAL SERVICES

(ii) Setting up

- X Install the gauge on the foundation. A suggested foundation is shown in Diagram 1.
- X Loosen the three enclosure securing screws and the enclosure.
- X The gauge is provided with a bull's eye level. Adjust the nuts on mounting bolts until gauge is level.
- X Connect lead to the rain gauge terminals, refer to Diagram 3 page 9, and to the recording device, in accordance with manufacturer's instructions.

VI TEST OPERATION

- X Manually tip the bucket a number of times, ensuring that each tip is being recorded and that the tilting mechanism is operating freely.
- X Replace and secure the enclosure.

VII MAINTENANCE

The only routine maintenance required is cleaning. The following items should be checked regularly for cleanliness:

- **Catch filter**
- **Syphon (refer diagram 2)**
- **Interior of bucket**
- **Top surface of adjusting screws**
- **Enclosure locking screws** - lightly lubricate after cleaning
- **All insect screens**

i. Dismantle Details

- (a) Unscrew nut
- (b) Lightly press stem down on surface until stem pops out of syphon body.
- (c) Remove stem from syphon body.
- (d) Unscrew cap
- (e) Clean all items

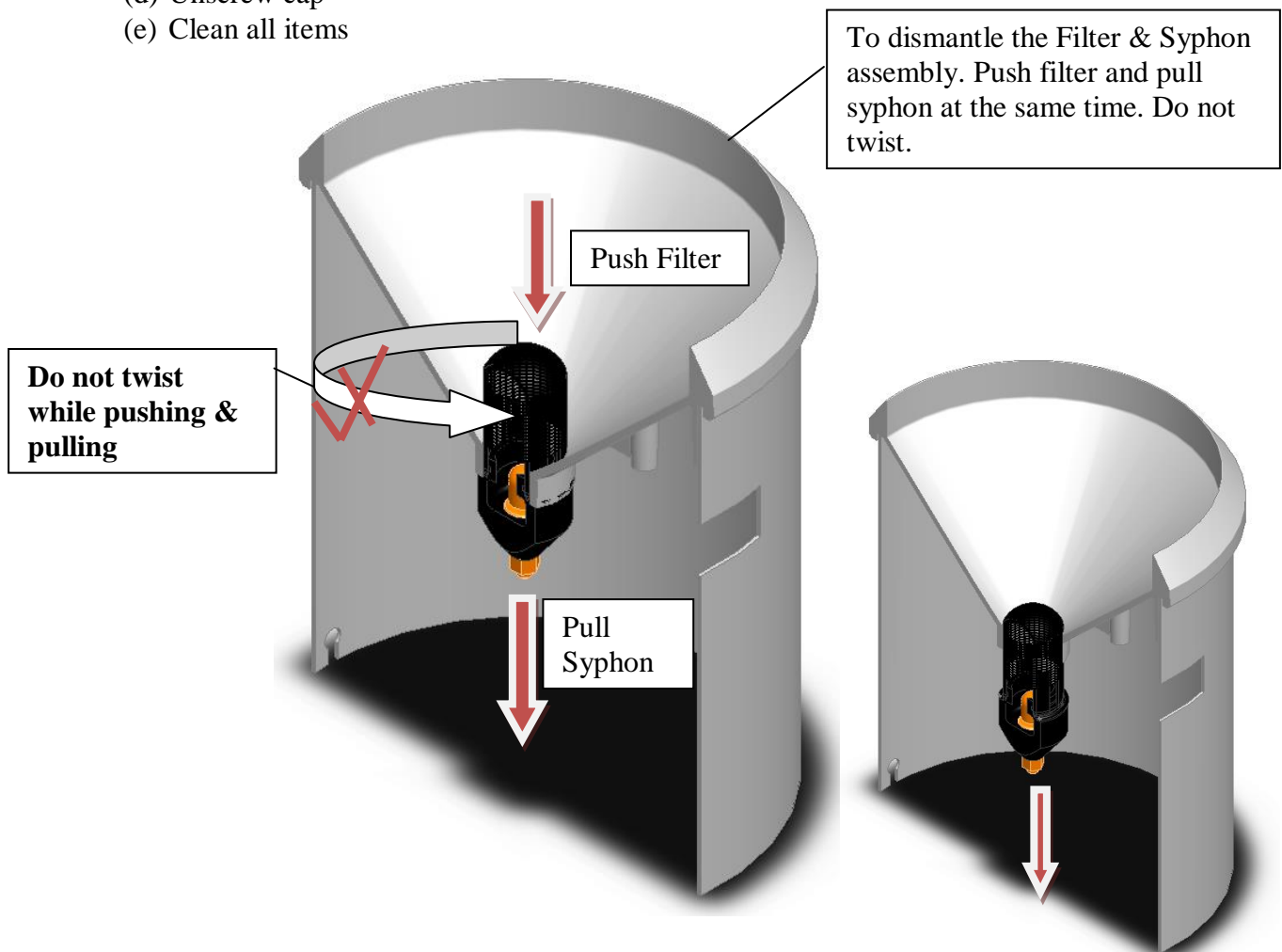

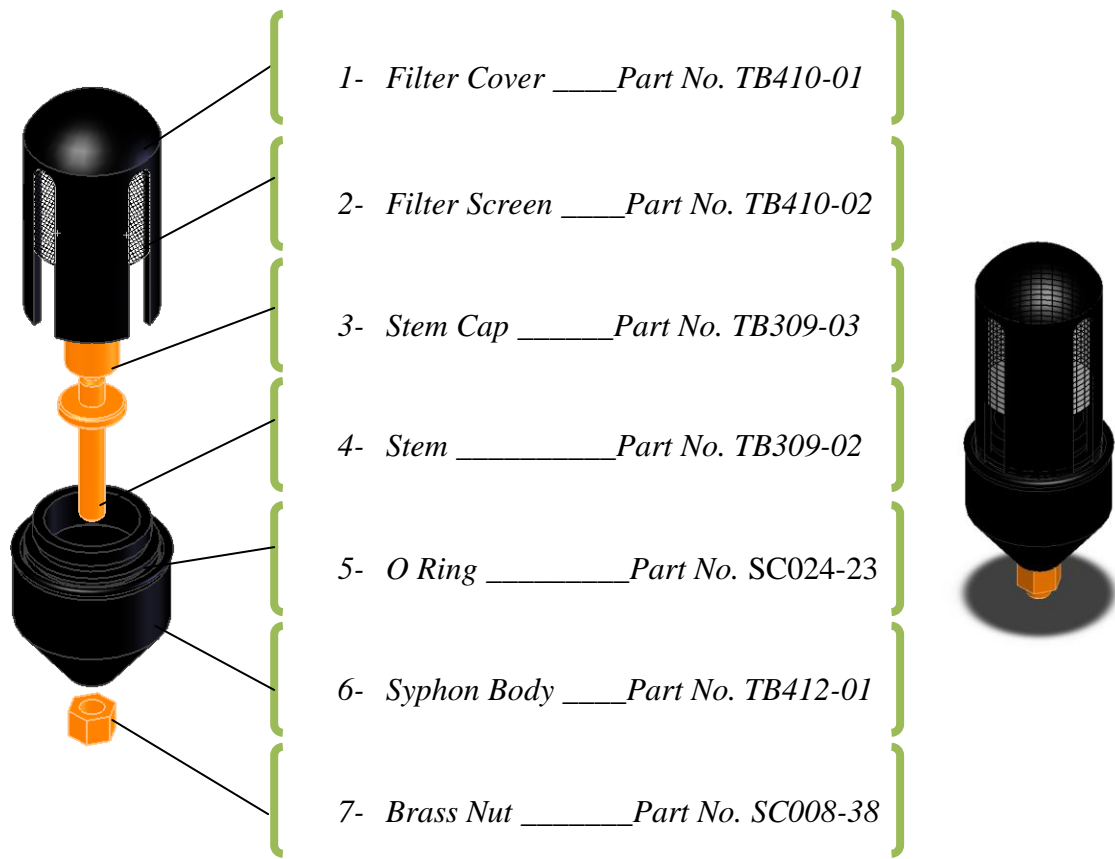
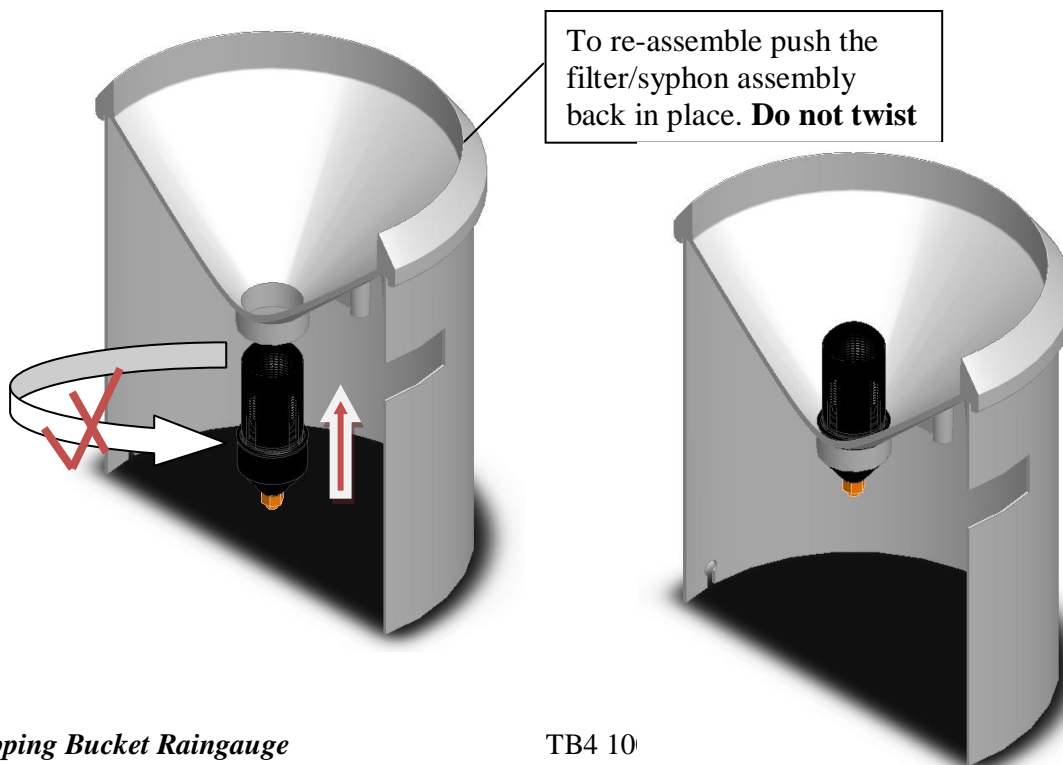

DIAGRAM 2

ii. Assembly Details

- (a) Screw cap on stem. Finger tight only.
- (b) Push stem into syphon body.
- (c) Replace nut and tighten. Do not over tighten.



VIII ELECTRICAL

Dual reed switches are provided for several reasons:

- Two isolated switches permit the control of two separate circuits; e.g. a local counter and a telemetry circuit.
- Parallel connection of both switches increases the current carrying capacity of the contact system if required.
- Parallel switch operation confers a degree of redundancy in locations where data from the raingauge is critical to flood warning etc.

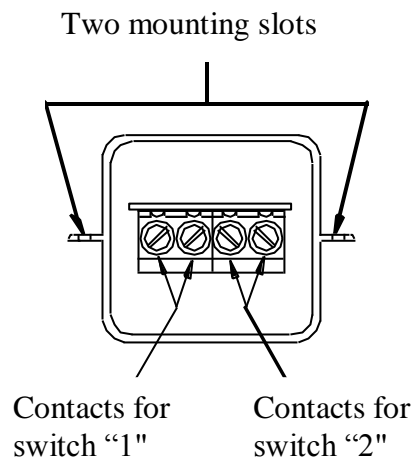

DIAGRAM 3

IX CALIBRATION

All gauges have been calibrated by Hydrological Services Pty Ltd, prior to despatch. The following products and services are available from Hydrological Services Pty Ltd:

- Field Calibration Device, Model TB320, for routine field check calibrations, supplied with operating instruction sheet refers to page FCD 110-01.
- Laboratory Calibration Unit, Model TB340, for calibration after servicing in workshops, supplied with operating manual.
- Recalibration Service at Hydrological Services' factory.

Please contact either Hydrological Services Pty Ltd or our local distributor for further information.

X TB4 PART LIST



Note:

The TB4 Raingauge is ordered with a synthetic ceramic coated brass bucket for 1mm size bucket only or chrome plated injection moulded non hydroscopic plastic ABS for the 0.2mm, 0.5mm or 0.01”.

Raingauge Part No.	Raingauge Description
TB4/0.2/P	Tipping Bucket Raingauge, bucket capacity 0.2mm, bucket type chrome plated injection moulded non hydroscopic plastic ABS UV stabilised
TB4/0.01/P	Tipping Bucket Raingauge, bucket capacity 0.01inch, bucket type chrome plated injection moulded non hydroscopic plastic ABS stabilised
TB4/0.5/P	Tipping Bucket Raingauge, bucket capacity 0.5mm, bucket type chrome plated injection moulded non hydroscopic plastic ABS stabilised
TB4/1.0/M	Tipping Bucket Raingauge, bucket capacity 1.0mm, bucket type synthetic ceramic coated brass

TB4 Base Part List

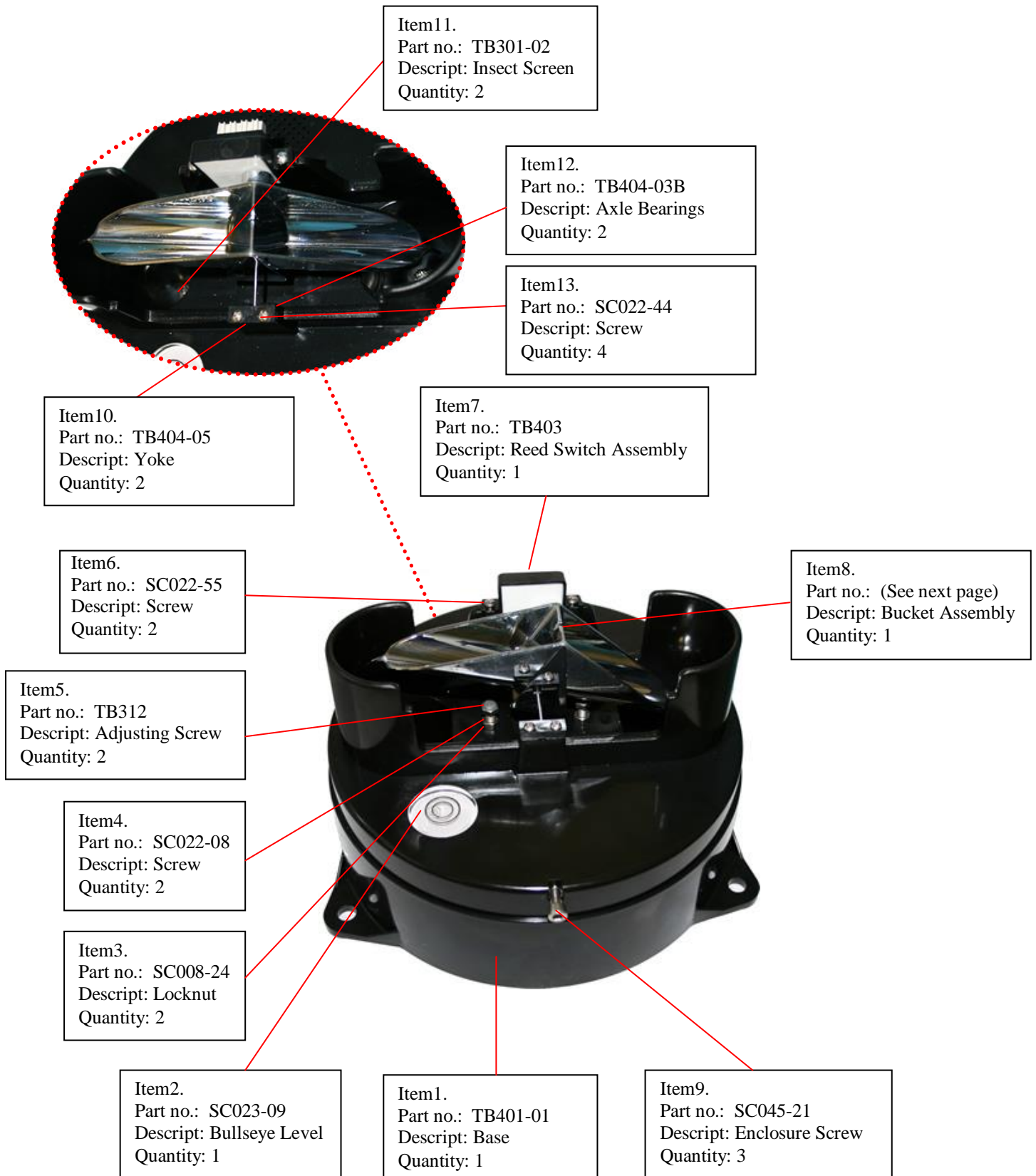

TB4 Bucket Part List

Item 14:
Part no: TB404
Descript: Bucket (0.2mm, 0.01")
or
Part no: TB405
Descript: Bucket (0.5mm)
Quantity: 1



ABS UV
Stabilised
Plastic Bucket

Item 15:
Part no: TB404-03
Descript: Bucket Axle
Quantity: 1

OR

Item 14a:
Part no: TB406
Descript: Bucket (1.0mm)
Quantity: 1



Metal Bucket
1mm only

Item 18:
Part no: TB404-03
Descript: Bucket Axle
Quantity: 1

Syphon Part List

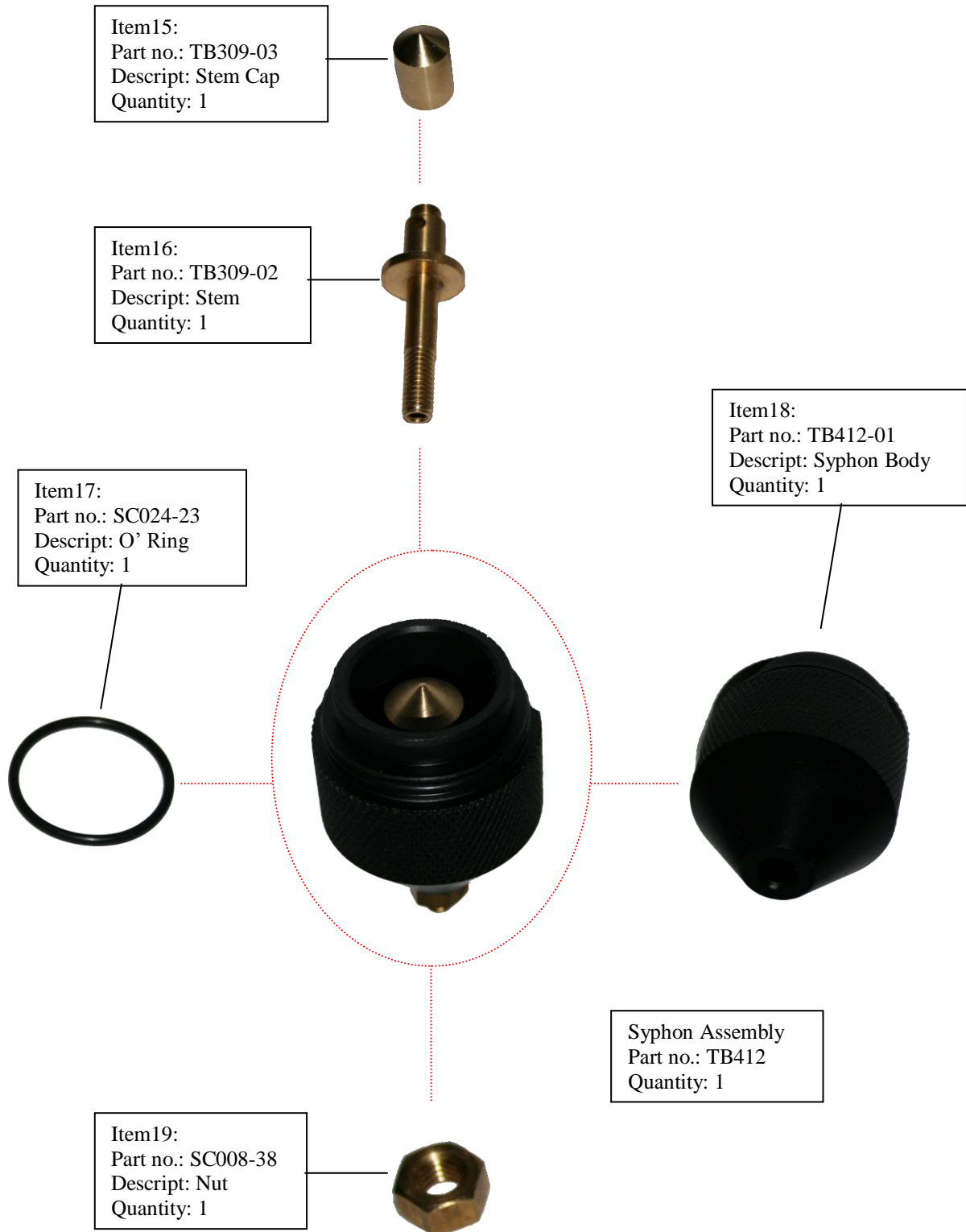

HYDROLOGICAL SERVICES

Filter Part List

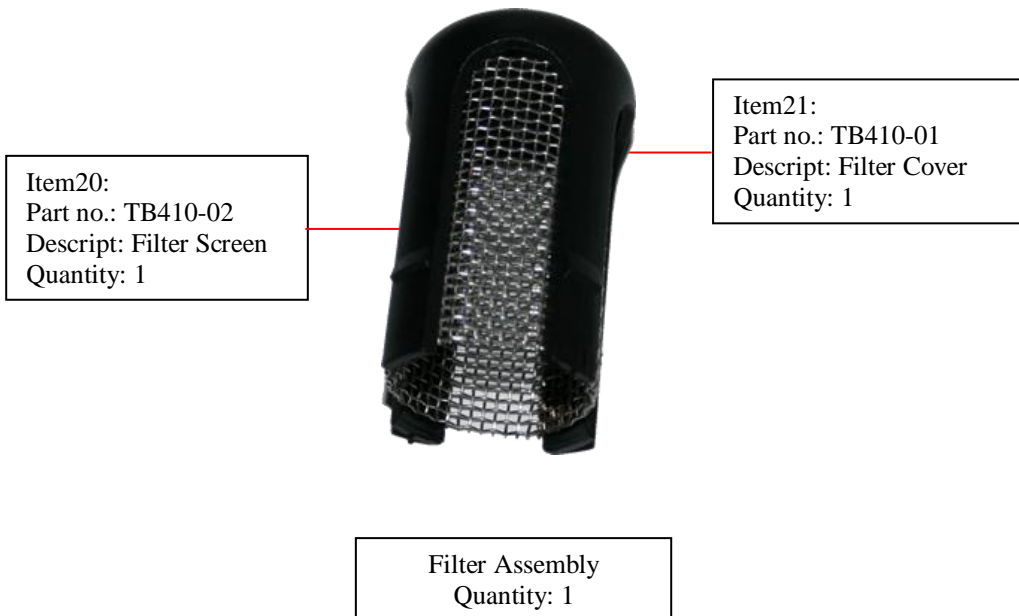

HYDROLOGICAL SERVICES

Enclosure Part List

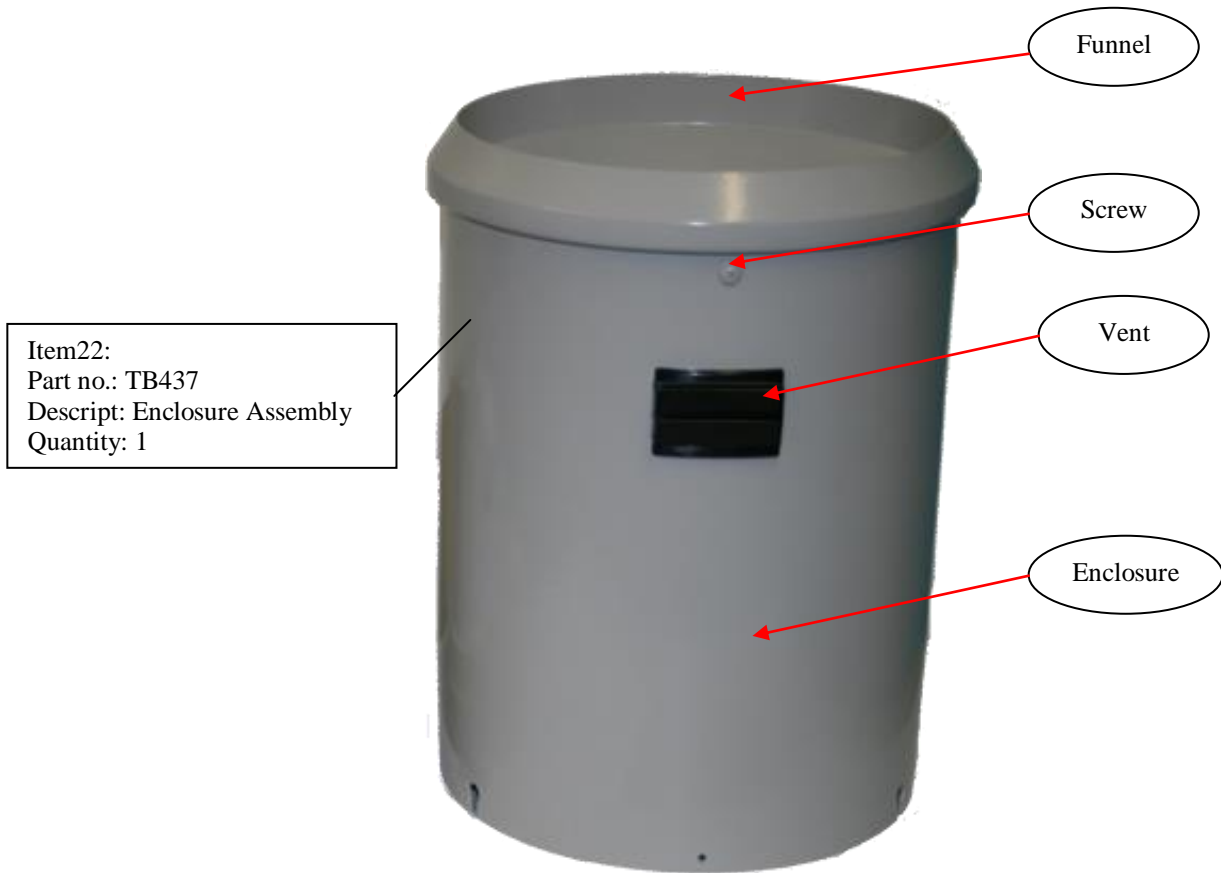

Part no.	Description	Quantity
TB337-01	Funnel	1
TB437-02	Enclosure	1
TB418-06	Vent	1
SC022-72	Screw	3

TB437 breakdown assembly

XI FIELD CALIBRATION DEVICE

NOTE: PLEASE WET RAINGAUGE PRIOR TO CALIBRATION

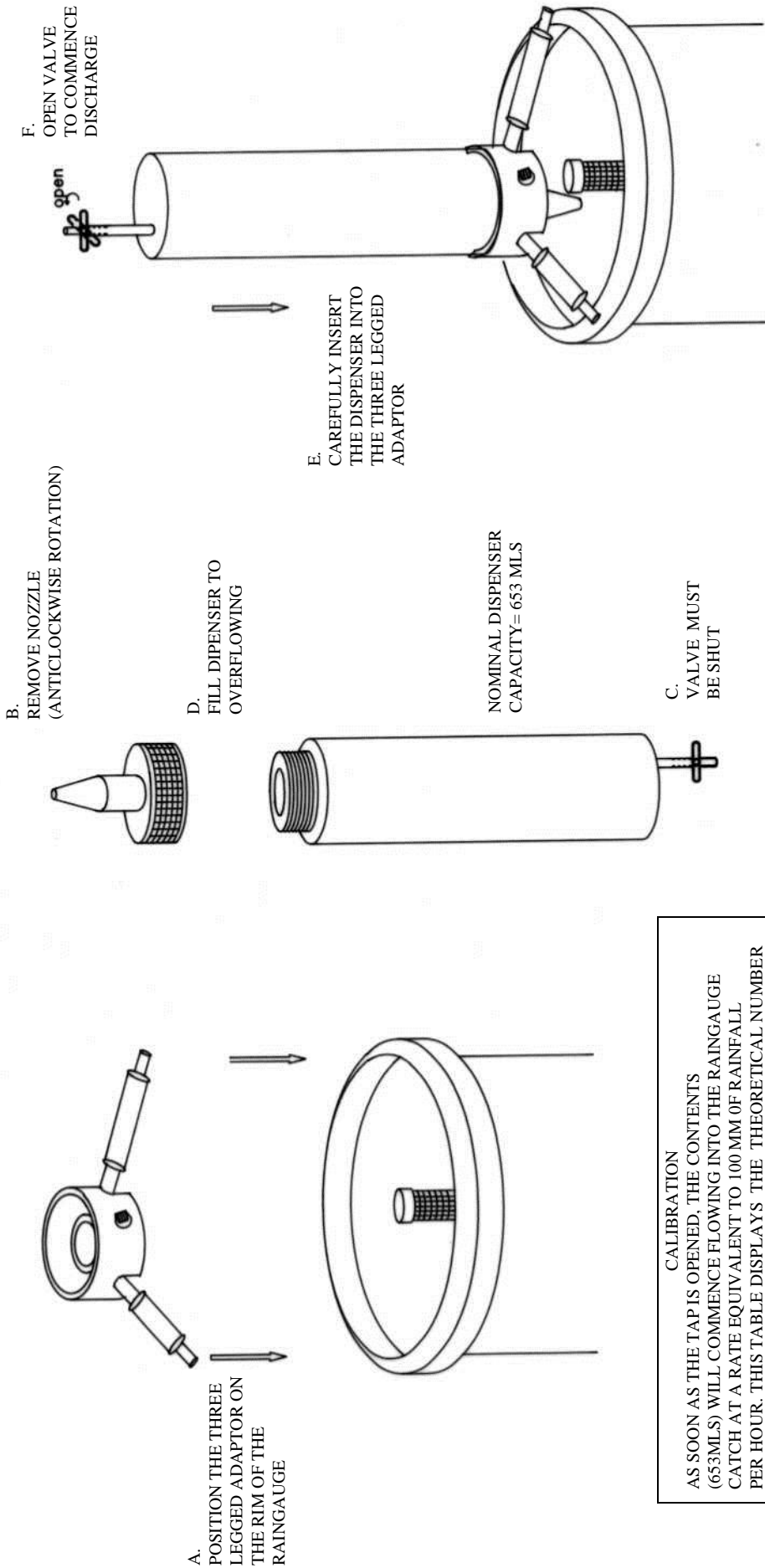

CALIBRATION		
AS SOON AS THE TAP IS OPENED, THE CONTENTS (653MLs) WILL COMMENCE FLOWING INTO THE RAINGAUGE CATCH AT A RATE EQUIVALENT TO 100 MM OF RAINFALL PER HOUR. THIS TABLE DISPLAYS THE THEORETICAL NUMBER OF BUCKET TIPS THAT SHOULD BE ACHIEVED.		
THEORETICAL NUMBER OF TIPS	200 MM CATCH	203 MM (80) CATCH
0.2 MM	103.9	100.9
0.5 MM	41.6	40.4
0.01 INCH	81.8	79.4
IF THE OBSERVED RESULTS ARE UNACCEPTABLE THEN REFER TO THE RAINGAUGE INSTRUCTION MANUAL FOR APPROPRIATE ADJUSTMENTS		

INSTRUCTION FOR TIPPING BUCKET
RAINGAUGE FIELD CALIBRATOR (FCD)

